



**BRUGERMANUAL
BEDIENUNGSANLEITUNG
USER MANUAL
MANUEL D'UTILISATEUR
BRUKERVEILEDNING
BRUKSANVISNING
KÄYTTÖOHJE
GEBRUIKERSHANDLEIDING**

Q - BE

attika[®]
FEUERKULTUR

RAIS[®]
ART  OF FIRE

Dansk	BRUGERMANUAL.....	6-31
Deutsch	BEDIENUNGSANLEITUNG.....	32-57
English	USER MANUAL	58-85
Français	MANUEL D'UTILISATEUR.....	86-111
Norsk	BRUKERVEILEDNING.....	112-137
Svenska	BRUKSANVISNING.....	138-163
Suominkielinen	KÄYTTÖOHJE	164-187
Vlaams	GEbruikersHANDLEIDING.....	188-213

DoP (DECLARATION of PERFORMANCE)..... 215

RAIS/attika Q-BE

Mærkeplade

CE Zeichen

Manufacturer's plate



Plaque signalétique

Merkeplade

Märkplät

Tyypikipi

Merksplaatje

14	 
EN 13240:2001+A2:2004, EC.NO: 161 Notified Body: 1235	
Produced at: RAIS A/S, Industrivej 20, 9900 Frederikshavn, Danmark	
<h3>Q-Be</h3>	
AFSTAND TIL BRÆNDBART, BAGVEG ABSTAND ZU BRENNBAREN BAUTEILEN, HINTEN DISTANCE TO COMBUSTIBLE BACK WALL DIST. ENTRE COMPOSANTS COMBUSTIBLES, ARRIÈRE AFSTAND TIL BRÆNDBART, SIDEVEG ABSTAND ZU BRENNBAREN BAUTEILEN, SEITE DISTANCE TO COMBUSTIBLE SIDE WALL DISTANCE ENTRE COMPOSANTS COMBUSTIBLES, COTÉ AFSTAND TIL BRÆNDBART, MØBLERING ABSTAND VORNE ZU BRENNBAREN MÖBELN DISTANCE TO FURNITURE AT THE FRONT DISTANCE ENTRE COMPOSANTS COMBUSTIBLES, DEVANT CO EMISSION (REL. 13% O ₂) CO EMISSION IN DEN VERBRENNUNGSPRODUKTEN (BEI 13%O ₂) EMISSION OF CO IN COMBUSTION PRODUCTS (AT 13%O ₂) EMISSION CO DANS LES PRODUITS COMBUSTIBLES (À 13%O ₂) STØV / STAUB / DUST / POUSSIÈRES: RØGGASTEMPERATUR / ABGASTEMPERATUR / FLUE GAS TEMPERATURE / TEMPÉRATURE DES GAZ DE FUMÉE: NOMINEL EFFEKT / HEIZLEISTUNG / THERMAL OUTPUT / PUISSANCE CALORIFIQUE: VIRKNINGSGRAD / ENERGIEFFIZIENZ / ENERGY EFFICIENCY / EFFICACITÉ ÉNERGÉTIQUE: DK: Brug kun anbefalede brændsler. Følg instrukserne i bruger manualen. Anordningen er egnet til røgassamleledning og intervalfyring. DE: Lesen und befolgen Sie die Bedienungsanleitung. Zeitbrandfeuerstätte. Nur empfohlene Brennstoffe einsetzen. UK: Fuel types (only recommended). Follow the installation and operating instruction manual. Intermittent operation. F: Veuillez lire et observer les instructions du mode d'emploi. Foyer à durée de combustion limitée, homologué pour cheminée à connexions multiples. Utiliser seulement les combustibles recommandés.	DK: 200mm SE BRUGERVEJLEDNING DE: 200mm SIEHE BEDIENUNGSANLEITUNG UK: 200mm SEE USER MANUAL FR: 200mm CONSULTEZ LE GUIDE DE L'UTILISATEUR DK: 200mm SE BRUGERVEJLEDNING DE: 200mm SIEHE BEDIENUNGSANLEITUNG UK: 200mm SEE USER MANUAL FR: 200mm CONSULTEZ LE GUIDE DE L'UTILISATEUR DK: 750mm SE BRUGERVEJLEDNING DE: 750mm SIEHE BEDIENUNGSANLEITUNG UK: 750mm SEE USER MANUAL FR: 750mm CONSULTEZ LE GUIDE DE L'UTILISATEUR 0,069 % / 862 mg/Nm ³ 16 mg/Nm ³ 300 °C 5,9 kW 80 % DK: BRÆNDE DE: HOLZ UK: WOOD FR: BOIS
Not to be used in a shared flue	
Raumheizer für feste Brennstoffe Appliance fired by wood Poêle pour combustibles solides	
15a B-VG VKF-NR: xxxxx Typ FCxxxFCxxx	Produced for: ATTIKA FEUER AG, Brunnmatt 16, CH-6330 Cham / RAIS A/S, Industrivej 20, DK-9900 Frederikshavn

Q-BE

Reservedelstegning / Ersatzteilzeichnung / Spare parts drawing /
Dessin des pièces de rechange / Reservdelsritning /
Varosapiitokset / Tekeningen van reserveonderdelen

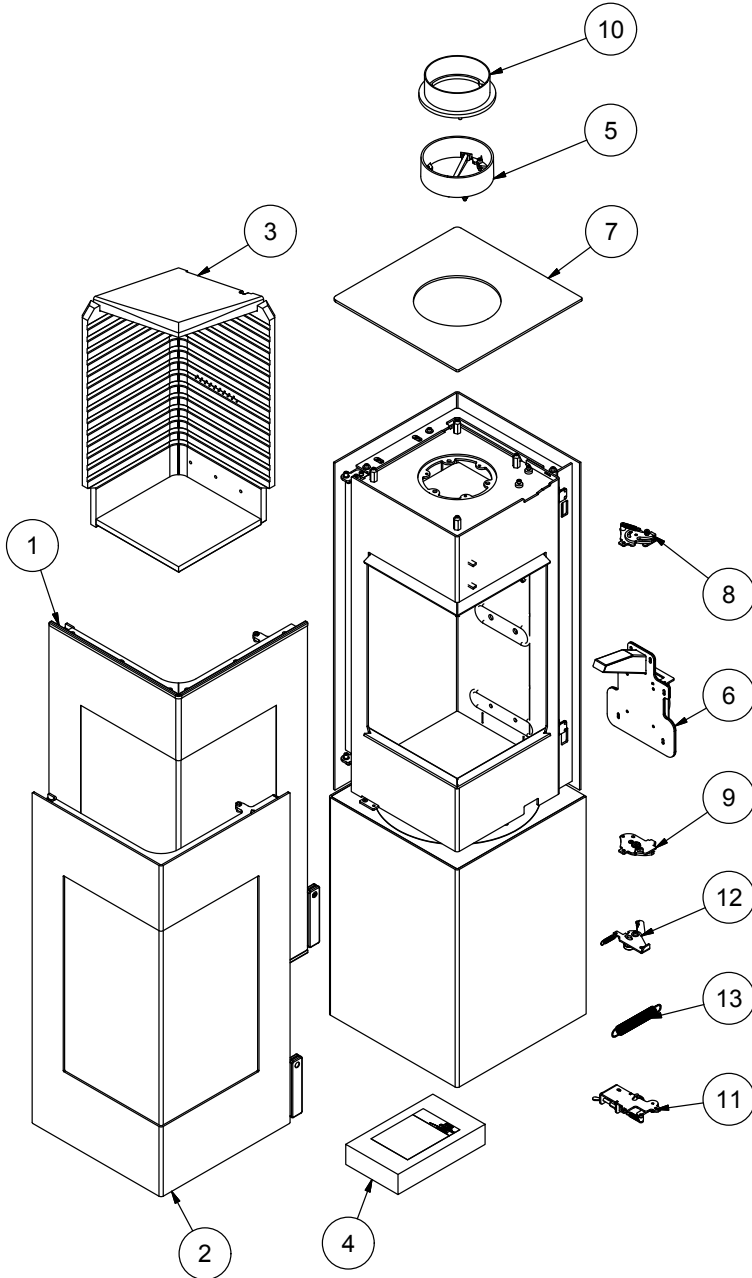

Q-BE

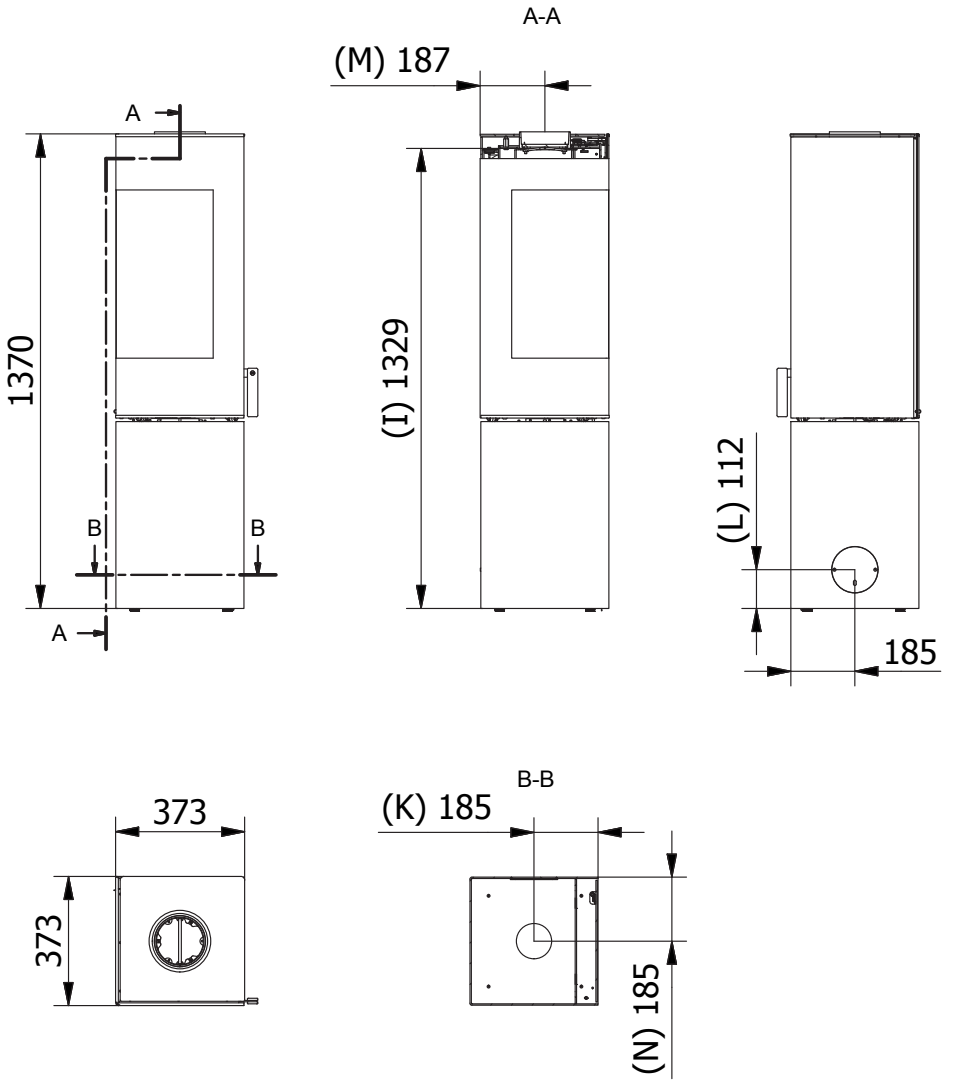

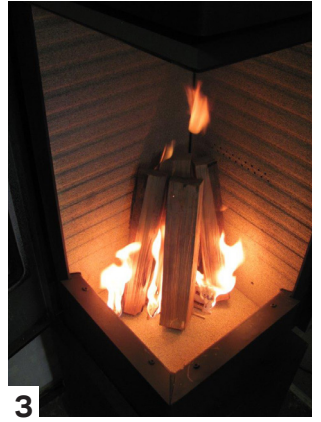

Q-BE

Revision : 8
Date : 12-04-2023

INTRODUCTION.....	56
WARRANTY.....	57
SPECIFICATIONS.....	58
DISTANCES.....	58
INSTALLATION INSTRUCTIONS.....	59
CONVECTION.....	60
CHIMNEY.....	60
INSTALLATION.....	61
INSTALLATION OF STOVE WITH SWIVEL BASE.....	62
INSTALLATION DISTANCE.....	63
NORMAL SET-UP (CORNER SETTING) - COMBUSTIBLE WALL.....	64
NORMAL SET-UP (CORNER SETTING) - NON-COMBUSTIBLE AND COMBUSTIBLE WALL.....	65
CORNER SETTING 45° - COMBUSTIBLE WALL.....	66
CORNER SETTING 45° - NON-COMBUSTIBLE SIDE WALL WITH COMBUSTIBLE WALL.....	67
INSTALLATION DISTANCE - COMBUSTIBLE CEILING.....	68
360° SWIVEL BASE.....	69
INSTALLATION DISTANCE IN CASE OF NON-COMBUSTIBLE WALL.....	70
FOR THE INSTALLER.....	71
FUEL.....	71
DRYING AND STORAGE.....	72
AUTOMATIC REGULATION OF COMBUSTION AIR (CLEVERAIR™).....	72
ROOM VENTILATION.....	73
FIRST USAGE.....	73
LIGHTING AND FUELLING.....	74
CONTROL.....	75
CLEANING AND CARE.....	77
CLEANING THE COMBUSTION CHAMBER.....	78
CLEANING OF FLUE WAYS.....	78
INTERRUPTION OF OPERATION.....	79
ACCESSORIES Q-BE.....	81
SPARE PARTS Q-BE.....	81

Introduction

Thank you for purchasing a RAIS/attika wood burning stove.

A RAIS/attika wood burning stove is more than just a heat source. It also shows that you care about design and quality in your home.

To make the most of your wood burning stove it is important that you read the manual thoroughly, before installing and using it.

In the case of warranty coverage, and for general queries regarding your wood burning stove, it is important that you know the stove's production number. We therefore recommend that you note down the number in the table below.

The production number is located on the back of the stove at the bottom.

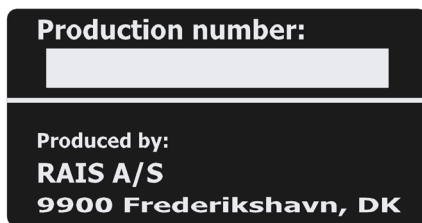

Date:

Distributor:

WARRANTY

RAIS/attika – wood-burning stoves are tested repeatedly in terms of safety, as well as material and manufacturing quality. We grant warranty on all models, starting with the date of installation.

The warranty refers to:

- documented malfunctions due to faulty manufacture
- documented material defects

The warranty does not cover:

- door and glass seals
- ceramic glass
- chamber lining
- appearance of the surface structure or natural stone texture
- appearance or changes of colour of the stainless steel or patina surfaces
- expansion noise

The warranty is invalidated in case of:

- damages, caused by overfiring
- damages, caused by external influence and the use of unsuitable fuels
- non-observance of statutory or recommended installation guidelines, and modifications to the wood-burning stove
- non-observance of service and care provisions

Please contact your retailer in the event of damage. We determine the way to repair the damage, in case of warranty claims. In the event of repair, we ensure proper and professional execution.

Warranty claims submitted for additionally delivered or repaired parts are subject to national/EU laws and regulations in terms of renewed warranty periods.

Please contact RAIS A/S for the applicable warranty provisions.

Specifications

DTI Ref.: 300-ELAB-2080-EN / 300-ELAB-2080-AEA	Q-BE
Nominal output (kW):	5.9
Min./Max. output (kW):	4 - 8
Heating area (m ²):	60 - 120
Stove's width/depth/height (mm):	373-373-1370
Combustion chamber's width/depth/height (mm):	239-239-505
Recommended amount of wood when fuelling (kg). Distributed on 3 logs of wood of approx. 19 cm	1.5
Min. uptake / Min. draught (Pascal):	-12
Weight (kg):	ca. 122
Efficiency (%):	80
CO-emission at 13% O ₂ (%)	0.069
NOx-emission at 13% O ₂ (mg/Nm ³):	53
Particles emission acc. to NS3058/3059 (g/kg):	1.4
Dust measured acc. to Din+ (mg/Nm ³):	14
Smoke gas mass flow (g/s):	5.1
Smoke gas temperature (°C):	300
Smoke gas temperature (°C) at flue collar:	360
Intermittent operation:	Refuelling should be undertaken within 46 minutes.

DTI, Danish Technological Institute
 Teknologiparken Kongsvang Allé 29, DK-8000 Aarhus C
 Denmark, www.dti.dk
 Telefon: +45 72 20 20 00
 Fax: +45 72 20 10 19

Distances

See drawing of the stove in front of the manual. All dimensions are stove dimensions without handle and set screws. Placing the stove on set screws/rotary base, will affect the height.

- I: Distance from floor to centre smoke outlet top
- K: Distance from back side to air intake bottom (air system)
- L: Distance from floor to air intake back side (air system)
- M: Distance from centre smoke outlet top to rear edge of top plate
- N: Distance from side to air intake bottom (air system)

Installation instructions

The following pages give instructions for the safe and proper installation of this heating appliance in the UK. These instructions cover the basic principles of installation, although detail may need slight modification to suit particular local site conditions. In all cases the installation must comply with current UK Building Regulations, Local Authority Byelaws and other specifications or regulations as they affect the installation of the stove. Please note that it is a legal requirement under England and Wales Building Regulations that the installation of the stove is either carried out under Local Authority Building Control approval or is installed by a Competent Person registered with a Government approved Competent Persons Scheme. HETAS Ltd operate such a Scheme and a listing of their Registered Competent Persons can be found on their website at www.hetas.co.uk.

It should be noted that the current Building Regulations requirements are given in Approved Document J. These requirements may also be met by adopting the relevant recommendations given in British Standards BS 8303 and BS EN 15287-1.

WARNING: Health and Safety Advice Notice

The installation of this heating appliance is governed by the Health and Safety at Work Act 1974. It is the responsibility of the installer to ensure that all requirements of this Act are met during the installation works. Attention is drawn in particular to the following:

Handling

The appliance is a heavy item and adequate facilities must be available for loading, unloading and site handling.

Fire Cement

Some types of fire cement are caustic and should not be allowed to come into contact with the skin. Protective gloves should be worn when handling fire cement. In case of contact with the skin wash immediately with plenty of water.

Asbestos

This stove contains no asbestos. If there is a possibility of disturbing any asbestos in the course of installation then please seek specialist guidance and use appropriate protective equipment.

Metal Parts

When installing or servicing this stove care should be taken to avoid the possibility of personal injury.

Important Warning – Preparatory Work and Safety Checks:

- This stove must not be installed into a chimney that serves any other heating appliance.
- It's recommended not have an extractor fan fitted in the same room as the stove as this can cause the stove to emit fumes into the room.
- If this appliance is installed into an existing chimney, the chimney must first be swept and examined for soundness and suitability before the appliance is installed (see also section headed "Chimney").

NOTE!!

This appliance may only be installed by a qualified RAIS dealer/installer.
See www.rais.com for dealer list.

Convection

RAIS/attika stoves are convection stoves. This means that the stove's back and side panels are not over-heated. Convection means that there is a circulation of air, which ensures that the heat is distributed more evenly throughout the entire room.

The **cold air** is sucked in at the base of the stove up through the convection channel, which runs along the stove's combustion chamber.

The **heated air** pours out at the top of the stove, which ensures a circulation of warm air throughout the room.

Chimney

The smoke flue is only installable on top of the stove. The stove has no rear outlet for the smoke flue.

The chimney is the driving force which makes the stove function. In order for the stove to perform satisfactorily the chimney height must be sufficient to ensure the correct draught of 14 to 18 Pa so as to clear the products of combustion and prevent problems of smoke emanating into the room when firing.

NOTE: A chimney height of not less than 4.5 metres measured vertically from the outlet of the stove to the top of the chimney should be satisfactory. Alternatively the calculation procedure given in BS 5854:1980 may be used as the basis for deciding whether a particular chimney design will provide sufficient draught.

The outlet from the chimney should be above the roof of the building in accordance with the provisions of Building Regulations Approved Document J.

If installation is into an existing chimney then it must be sound and have no cracks or other faults which might allow fumes into the house. Older properties, especially, may have chimney faults or the cross section may be too large i.e. more than 230 mm x 230 mm. Remedial action should be taken, if required, seeking expert advice, if necessary. If it is found necessary to line the chimney then a flue liner suitable for solid fuel must be used in accordance with Building Regulations Approved Document J.

Any existing chimney must be clear of obstruction and have been swept clean immediately before installation of the stove. If the stove is fitted in place of an open fire then the chimney should be swept one month after installation to clear any soot falls which may have occurred due to the difference in combustion between the stove and the open fire.

If there is no existing chimney then either a prefabricated block chimney in accordance with Building Regulations Approved Document J or a twin walled insulated stainless steel flue to BS 1856-1 can be used. These chimneys must be fitted in accordance with the manufacturer's instructions and Building Regulations.

A single wall metal fluepipe is suitable for connecting the stove to the chimney but is not suitable for using for the complete chimney. The chimney and connecting fluepipe must have a minimum diameter of 125 mm. Any bend in the chimney or connecting fluepipe should not exceed 45°. 90°bends should not be used.

Combustible material should not be located where the heat dissipating through the walls of fireplaces or flues could ignite it. Therefore when installing the stove in the presence of combustible materials due account must be taken of the guidance on the separation of combustible material given in Building Regulations Approved Document J and also in these stove instructions.

If it is found that there is excessive draught in the chimney then either an adjustable flue damper or alternatively a draught stabiliser should be fitted. The adjustable flue damper should not close off the flue entirely but should in its closed position leave a minimum continuous opening free area of at least 20 % of the total cross sectional area of the flue or fluepipe.

Adequate provision e.g. easily accessible soot door or doors must be provided for sweeping the chimney and connecting fluepipe.

You should also familiarise yourself with the draught conditions for chimneys with 2 flues.

The flue outlet spigot is either 150 mm (6") in diameter, or 129 mm (5") in diameter.

For strong draughts, the chimney or flue should be fitted with a draught stabiliser. In which case, it is important to ensure that there is a free flow-through area of minimum 20 cm² when the regulating gate is shut. Otherwise, the fuel energy may not be used optimally. If, at any time, you are unsure about the condition of the chimney, you should contact a chimney sweep.

Remember that access to the access door should be kept clear.

Installation

The stove is delivered on a swivel base, locked ex works. The swivel base can be altered to either 90° or 360° by removing the lock screws on the bottom of the stove. See separate instructions in the next section.

The stove is a free standing stove and is placed on fireproof material.

This appliance may only be installed by a qualified Rais dealer/installer, otherwise the warranty is voided.

When installing the appliance, all local rules and regulations, including those referring to national and European standards need to be complied with. Local authorities and a chimney specialist should be contacted prior to set up.

It is prohibited to carry out unauthorised alterations to the stove.

There must be plenty of fresh air in the room where the stove is being installed, in order to ensure proper combustion. Note that any mechanical exhaust ventilation - e.g. an extraction hood - may reduce the air supply. Any air grates must be placed in such a manner, that the air supply is not blocked.

The floor structure must be able to carry the weight of the wood burning stove, as well as the weight of a chimney, if necessary. If the existing floor construction doesn't meet this requirement, suitable measures (e.g. load distributing plate) shall be taken to achieve it. RAIS recommends to consult a building expert.

When you choose where to set up your RAIS/attika wood burning stove, you should consider the heat distribution to the other rooms. This will enable you to get the best use out of your stove.

The stove should be set up at a safe distance from inflammable materials.

See the manufacturer's plate on the wood burning stove.

Upon receiving the stove must be inspected for defects.

Installation of stove with swivel base

Swivel base for 90° turning.

Open the backplate of the base.



Remove the 2 wing screws (lock screws).



Check that the stove can rotate.

Swivel base for 360° turning.

Open the backplate of the base.
Remove the 2 wing screws, if mounted.
Remove the air box (4 screws).



Remove the 2 lock pins with a flathead screwdriver.



Check that the stove can rotate.
Remount the air box (4 screws).

Installation distance

To determine whether the wall next to where the stove is going to be installed is flammable, you should contact your building contractor or the local building authorities.

The hearth should be able to accommodate the weight of the stove. The chimney must be independently supported by wall brackets or a ceiling support plate. The weight of the stove is indicated in the brochure.

The stove should always be installed on a non-combustible hearth of a size and construction that is in accordance with the provisions of the current UK Building Regulations Approved Document J.

If the stove is to be installed on a wooden floor, it must be covered with a non-combustible material at least 12 mm thick, in accordance with UK Building Regulations Approved Document J, to at distance of 300 mm in front of the stove and 150 mm to each side measuring from the door of the combustion chamber.

The clearance distances to combustible material beneath, surrounding or upon the hearth and walls adjacent to the hearth should comply with the guidance on the separation of combustible material given in UK Building Regulations Approved Document J and also in these stove instructions.

It must be ensured that no combustible objects (eg. furniture) are placed closer than the distances given in the following tables (risk of fire).

Normal set-up (corner setting) - combustible wall

	Uninsulated flue
A. Distance to furniture (min.)	750 mm

Distance to flammable materials (min.)

B. in front (floor)	if distances are not shown, national/local regulations are followed
C. to the side (floor)	if distances are not shown, national/local regulations are followed
D. to the rear (wall)	200 mm
E. to the side of the wall	200 mm

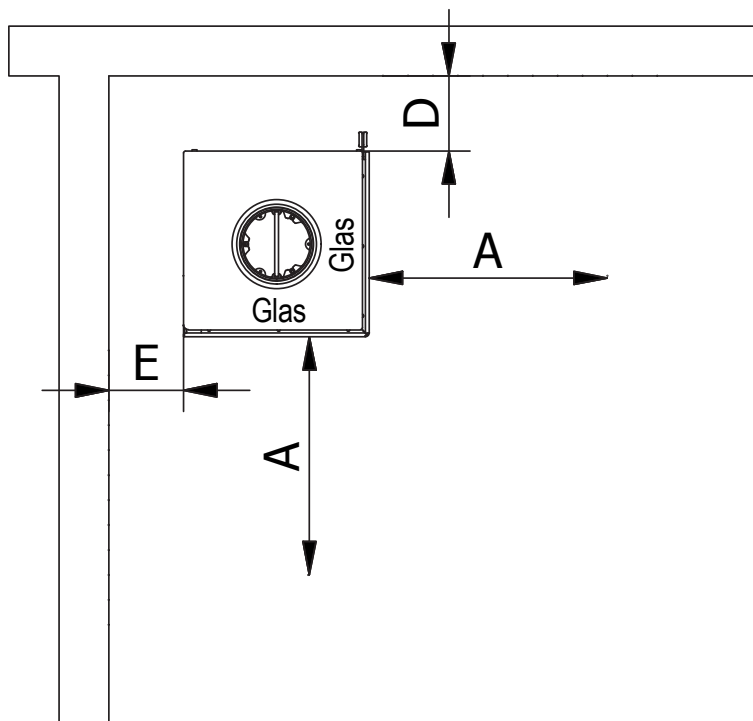

Normal set-up (corner setting) - non-combustible and combustible wall

	Uninsulated flue
Distance (min.) to non-flammable materials (X)	Distance (min.) to flammable materials (Y)
50 mm	325 mm
100 mm	250 mm

For example:

at distance 50mm (X) to the non-combustible wall, the distance in front of the stove to the combustible wall must be 325 mm (Y).

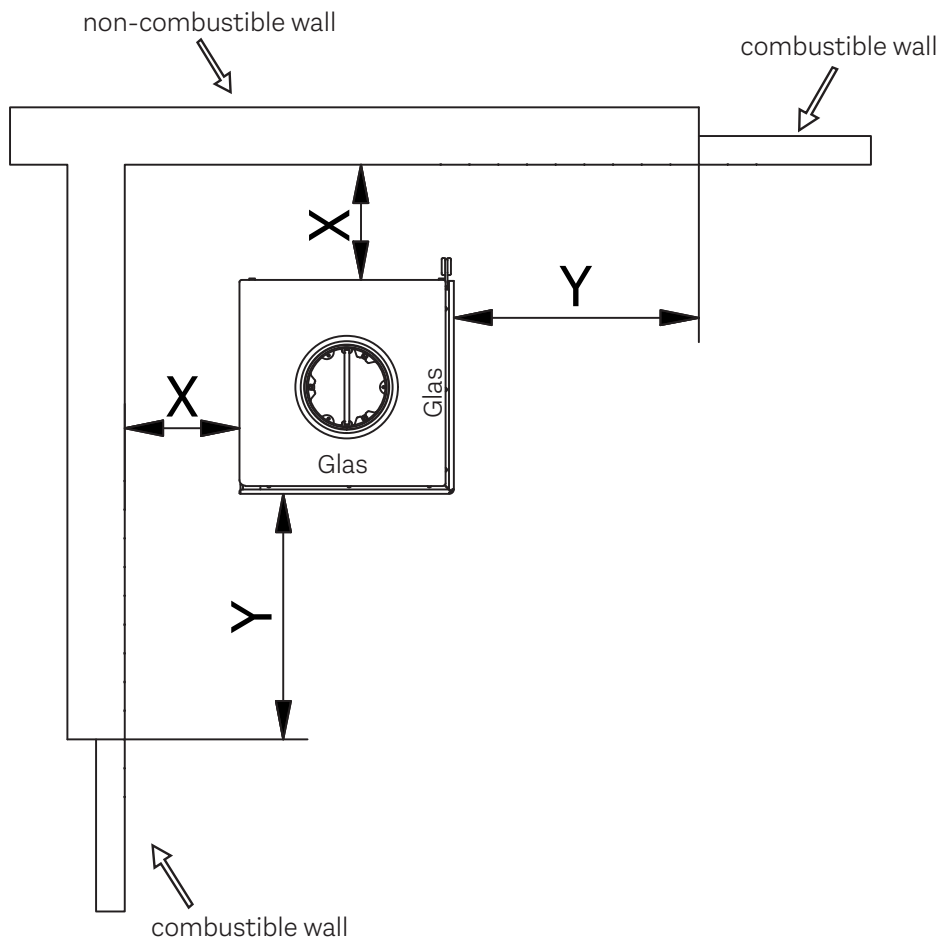

Corner setting 45° - combustible wall	
	Uninsulated flue
A. Distance to furniture (min.)	750 mm

Distance to flammable materials (min.)

B. in front (floor)	if distances are not shown, national/ local regulations are followed
C. to the side (floor)	if distances are not shown, national/ local regulations are followed
D. to the rear (wall)	60 mm
E. to the side of the wall	150 mm

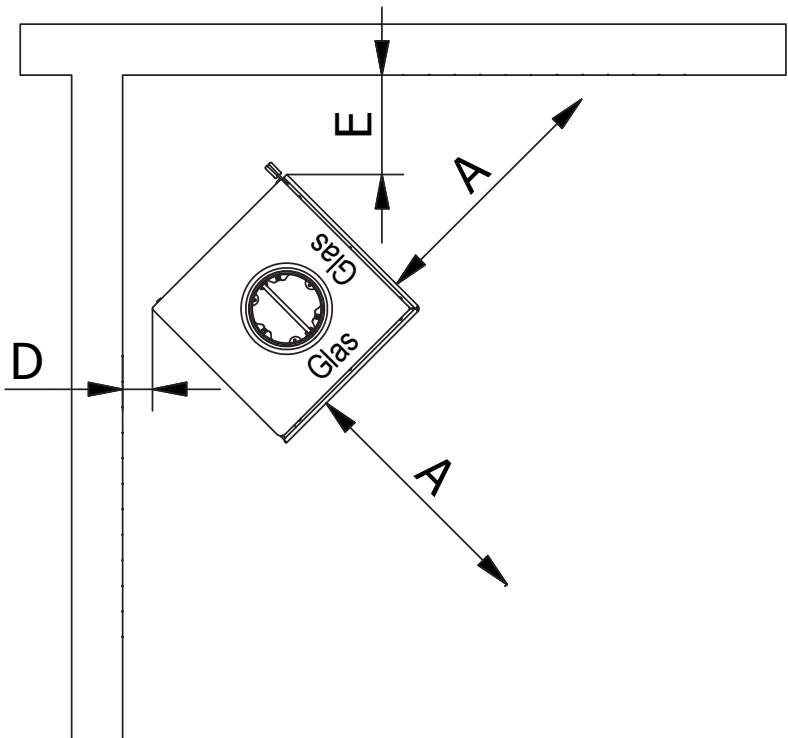

Corner setting 45° - non-combustible side wall with combustible wall

	Uninsulated flue
Distance (min.) to non-flammable materials (X)	Distance (min.) to flammable materials (Y)
50 mm	650 mm
100 mm	600 mm
150 mm	575 mm
200 mm	530 mm

For example:

at distance 50mm (X) to the non-combustible wall, the distance in front of the stove to the combustible wall must be 650 mm (Y).

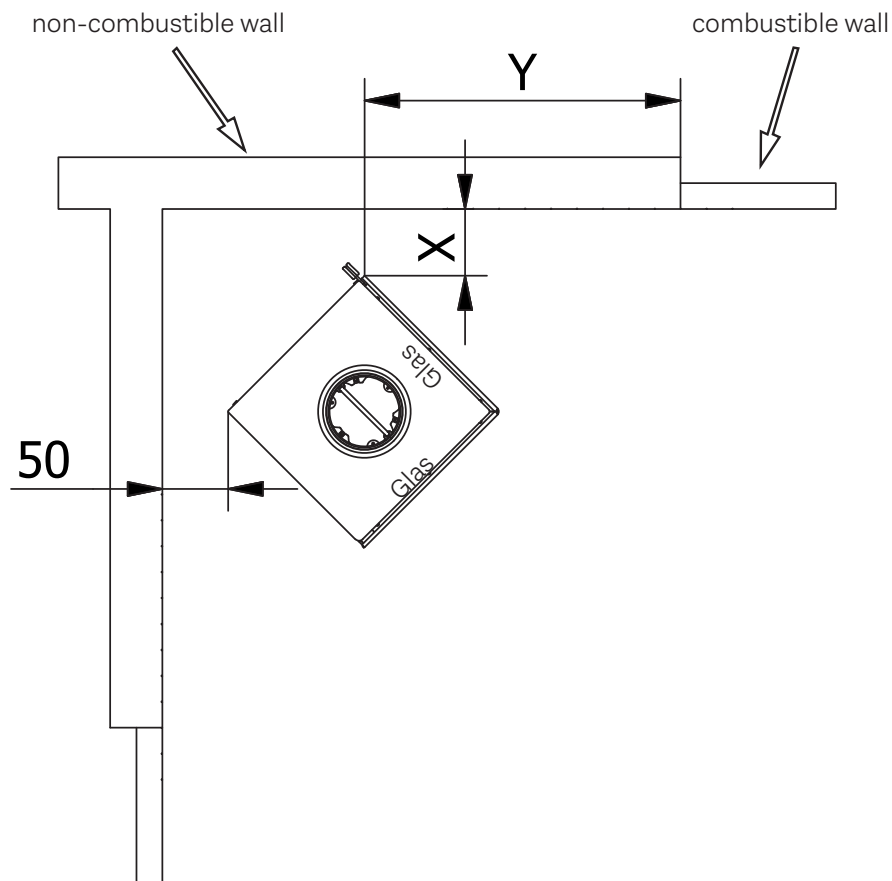

Installation distance - combustible ceiling	
---	--

	Uninsulated flue
--	------------------

Distance to flammable materials (min.)

H. to the ceiling	500 mm
-------------------	--------

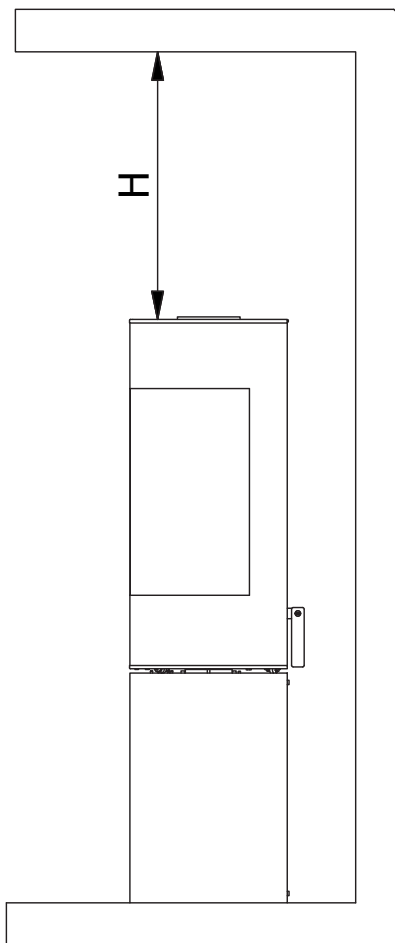

360° swivel base	
	Uninsulated flue
A. Distance to furniture (min.)	750 mm

Distance to flammable materials (min.)

B. in front (floor)	if distances are not shown, national/ local regulations are followed
C. to the side (floor)	if distances are not shown, national/ local regulations are followed

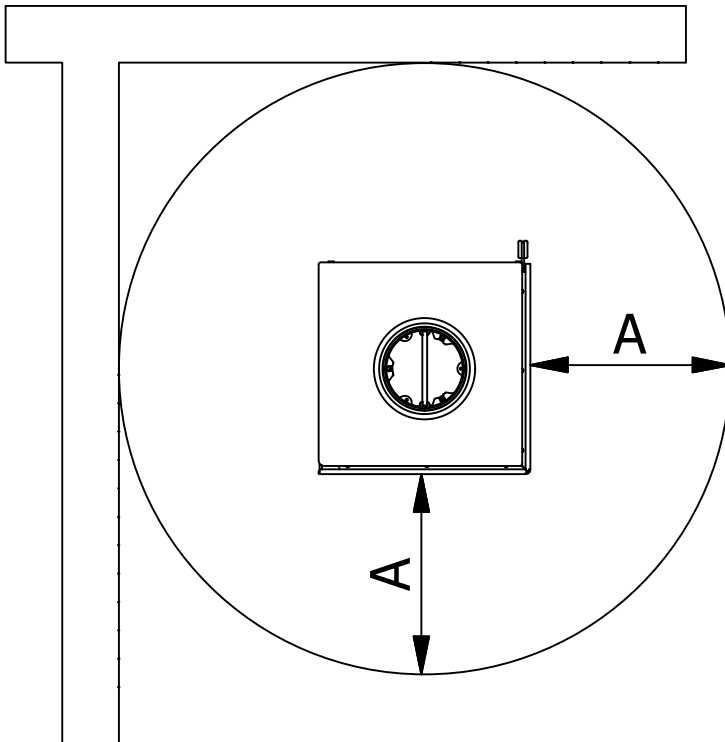

Installation distance in case of non-combustible wall

We recommend a minimum distance to non-combustible material of 50 mm (F) for cleaning considerations.

It should always be possible to access the access door.

Normal corner setting

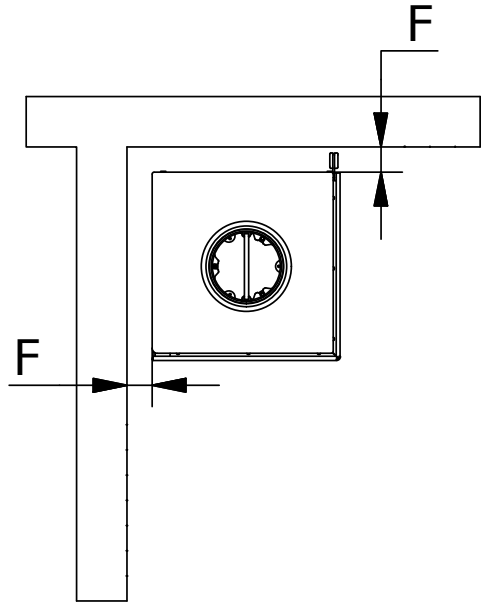

Corner setting 45°

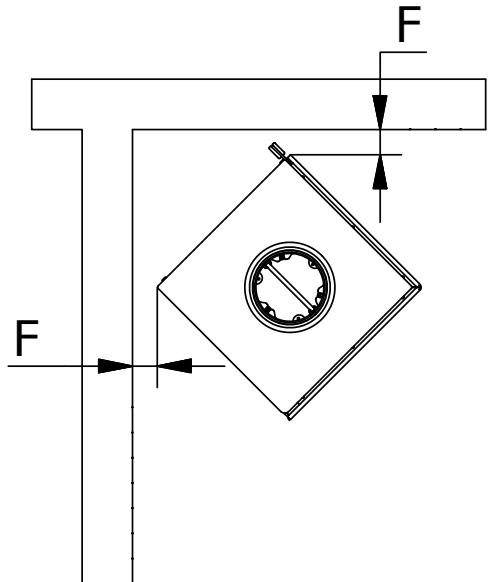

For the Installer

Finally before firing the stove for the first time a check should be made to ensure that the assembly and stove installation has been satisfactory and that there are no leaks in any seals in the appliance and appliance connections to the chimney.

Ensure that the appliance and chimney flue are functioning correctly before finally handing over to the user. If necessary read the later parts of this manual for guidance on care required when first lighting.

Inform the user that the appliance has been commissioned and ready to use and give instruction on the safe operation of the stove.

These Instructions must be left with the user and the user should be instructed to keep them in a safe place.

Operating instructions

Please note that HETAS Ltd Appliance Approval only covers the use of dry seasoned wood logs on this appliance. HETAS Ltd Approval does not cover the use of other fuels either alone or mixed with the wood logs, nor does it cover instructions for the use of other fuels.

Fuel

The stove has been tested in accordance with EN 13229:2001, EN 13229:2001/A1:2003, EN 13229:2001/A2:2004, and NS 3058 for stoking split, dried birchwood, and is approved for broad-leaved/coniferous tree wood. The firewood must have a water content of 15-20 % and its max. length should be 25 cm when leaning them up against the back panel.

Stoking with wet firewood causes both soot, environmental pollution and bad fuel economy. Freshly cut wood contains approx. 60-70% water and is thoroughly unsuitable for stoking. Count min. 1-2 years of storage time for newly cut wood before using. Wood with a diameter of more than 100 mm should be split. Regardless of wood size, it should always have at least one surface area free of bark.

We do not recommend stoking with painted, laminated or impregnated wood, wood with a synthetic surface, painted refuse wood, chipboard, plywood, domestic waste, paper briquettes and pit coal, as this will produce malodorous smoke, which could be poisonous.

When firing with the above-mentioned items and amounts larger than those recommended, the stove is subjected to a larger amount of heat, which results in a higher chimney temperature and lower efficiency. This can result in the stove and chimney becoming damaged and would void the warranty.

The calorific value of the firewood is closely connected to the moisture level of the firewood. Moist firewood has a low heat value. The more water the wood contains, the more energy it takes for this water to vaporise, resulting in this energy being lost.

ONLY USE RECOMMENDED FUELS

The following table shows the calorific value of different types of wood, which have been stored for 2 years, and which have a residual moisture of 15-17%.

Wood	Kg dry wood pr. m³	compared to beech/oak
Hornbeam	640	110%
Beech and oak	580	100%
Ash	570	98%
Maple	540	93%
Birch	510	88%
Mountain pine	480	83%
Fir	390	67%
Poplar	380	65%

1 kg of wood yields the same heat energy irrespective of wood type.
1 kg beech merely takes up less space than 1 kg of fir.

Drying and storage

Drying wood takes time. Proper air drying takes approx. 2 years.

Here are some tips:

- Store the wood sawn, split and stacked in an airy, sunny place, which is protected against rain (the south side of the house is particularly suitable).
- Store the firewood stacks at a hand's breadth apart, as this ensures that the air flowing through takes the moisture with it.
- Avoid covering the firewood stacks with plastic, as this prevents the moisture from escaping.
- It is a good idea to bring the firewood into the house 2-3 days before you need it.

Automatic regulation of combustion air (CleverAIR™)

This stove is equipped with an independent and self-regulating air damper. Hence there is no damper handle. You only need to place dried wood and light it. The rest is done by the CleverAIR™ technique.

The primary air is added to the primary combustion zone at the bottom of the burning chamber, i.e. the bed of glowing embers. This cold air is only used in the lighting stage.

Secondary air is the air, added to the gas combustion zone, meaning air, which contributes to the combustion of the pyrolysis gasses (preheated air, used for cleaning the glass and combustion). This air is sucked through the damper and is pre-heated through the side channels and then emitted as hot scavenging air onto the glass. The hot air rinses the glass and keeps it soot-free.

Tertiary air at the back of the burning chamber at the top (2 rows of holes) ensures the combustion of the final gas residues.

The pilot nozzles are placed in the back plate and front of the combustion chamber. They ensure that the bed of glowing embers is fed with air and therefore holds a high temperature. It provides a quick start when refuelling and reduces the risk of fire going out.

CleverAIR™ ensures an optimal air mixture and a clean combustion at any burning phase. Due to the bi-metal regulated burning automation an incorrect operation is excluded.

Room ventilation

There must not be an extractor fan fitted in the same room as the stove as this can cause the stove to emit smoke and fumes into the room.

The stove requires a permanent and adequate air supply in order for it to operate safely and efficiently.

In accordance with current Building Regulations the installer may have fitted a permanent air supply vent into the room in which the stove is installed to provide combustion air. This air vent should not under any circumstances be shut off or sealed.

First usage

A careful start pays off. Start with a small fire, so that the wood burning stove can get accustomed to the high temperature. This gives the best start and any damage is avoided.

Be aware that a strange but harmless odour and smoke concoction may emanate from the surface of the stove, the first time you fire up. This is because the paint and materials need to harden. The odour disappears quickly, but you should check the ventilation and draught, if possible. See also, the IMPORTANT warning notice below about persistent fumes.

During this process you must be careful not to touch the visible surfaces/glass (very hot!), and it is recommended that you regularly open and close the door to prevent the door seal from sticking.

The stove may also produce “clicking noises” during heating and cooling, caused by the large temperature differences which the material is subjected to.

Never use any type of liquid fuel for kindling or maintaining the fire. There is a danger of explosion.

The stove gets very hot when in use always wear protective gloves when tending the stove.

If the stove has not been used for a while, follow the steps as if you were using it for the first time.

IMPORTANT - Warning Note!

Properly installed, operated and maintained this appliance will not emit fumes into the dwelling. Occasional fumes from de-ashing and re-fuelling may occur. However, persistent fume emission is potentially dangerous and must not be tolerated. If fume emission does persist, the following immediate actions should be taken:

1. Open doors and windows to ventilate room.
2. Let the fire out or eject and safely dispose of fuel from the appliance.
3. Check for flue or chimney blockage, and clean if required.
4. Do not attempt to relight the fire until the cause of the fume emission has been identified and corrected. If necessary seek expert advice.

IMPORTANT - Warning Note!

Do not use an aerosol spray on or near the stove when it is alight.

IMPORTANT - Safety advice!

When using the stove in situations where children, aged and/or infirm persons are present a fireguard must be used to prevent accidental contact with the stove. The fireguard should be manufactured in accordance with BS 8423:2002 (Replaces BS 6539).

Lighting and fuelling

See photos at the front of manual.

NOTE: If aircsystem is connected, the valve must be open.

TIPS before firing up:

Open a door or window close to the wood burning. If there is a “storm” in the stove coming from the chimney, it is advisable to place a screwed-up piece of newspaper between the upper baffle plate and the chimney, set the paper on fire, and wait until you hear a “rumbling” noise in the chimney. This means that there definitely is a draught in the chimney and you avoid smoke in the room.

- Open the door fully until it is locked in the open position.
- Start by placing approx. 1.1 kg of wood (4 pcs. of split kindling sticks) vertically at the bottom of the combustion chamber (photo 1). Place 3 fire lighters or similar near the wood.
- Light the fire (photo 2+3).
- Close the door and leave it ajar by pulling the door handle (photo 4).
- When the fire has caught the kindling wood close the door completely (after approx. 5 min., depending on the draft conditions in the chimney).
- When the last flames are extinguished and there is a nice layer of embers (photo 5), add 2 pieces wood (about 1 ½ kg) after approx. 15-20 min (photo 6).
- Close the door completely.
- If necessary keep the door open for a few minutes to start the fire (photo 7).

NOTE!!

If the fire has burned down too low (too small an ember), it may take longer time to get the fire going again.

When firing the smoke out of the chimney should be almost invisible; just a 'flicker' in the air is observed.

When refueling, open the door carefully to avoid smoke escaping. Never add wood while it is burning (flames!) in the stove.

RAIS recommends to refuel with 2 pieces wood - approx. 1 ½ kg - within 46 minutes (intermittent operation).

ATTENTION!!

Keep an eye on the stove when lighting.

During operation the door should always remain shut.

Control

Look for signs that indicates a correct firing in the stove:

- ash is white
- the walls of the combustion chamber is free of soot

Conclusion: the wood is sufficiently dry

Recommended amount of wood for stoking the fire

To find the recommended amount of wood for stoking the fire, please refer to the table below.

The recommended amount of wood to burn after lighting depends on your stove model. Based on the nominal output of your stove, you can read the recommended amount of wood to use for stoking.

The nominal output can be read on both your

oven's CE marking plate and our website.

STOKING TIME INTERVAL

The recommended fuel quantity should be stoked within 45–60 minutes from the last stoking.

The exact interval for when to stake the volume of wood can be seen under "Specifications" in the stove's installation manual under "Intermittent operation".

RECOMMENDED VOLUME OF WOOD FOR STOKING WOOD-BURNING STOVES

Find the nominal output of your wood-burning stove to determine the recommended volume (kg) of wood you can burn.

Nominal output, kW (according to the CE marking plate)	Recommended volume of wood (kg)*
4 - 4.9	1.3 - 1.5
5 - 5.9	1.3 - 1.5
6 - 6.9	1.8

* The exact indication of the recommended volume of wood to be stoked (kg) is found in your stove's installation manual under "Specifications".

EXAMPLE OF DETERMINING THE RECOMMENDED VOLUME OF WOOD

By reading the CE marking plate on the Q-Be (or finding the nominal output on our website), you will see that the stove has a nominal output of 5.9 kW. See an example of a CE marking plate on the next page.

Based on the nominal output, the recommended volume of firewood for wood-burning stoves found in the table is 1.3–1.5 kg.

Nominal output, kW	Recommended volume of wood (kg)
5 - 5.9	1.3 - 1.5

Do not overfire

Do not overfire the stove. The maximum volume of wood that may be burned in your stove can be found in the table below. If you stoke more wood than the volume specified in the table, you will overfire your stove.

If you exceed the limits for the volume of wood specified in the table, the stove will be deemed overfired and will no longer be covered by the manufacturer's warranty, as excessive heat can irreparably damage your stove.

The nominal output is found on both the CE mar-

king plate and our website.



www.rais.com

Nominal output, kW (according to the CE marking plate)	Max. kg of wood per hour	Number of pieces of firewood
4 - 4.9	2	Max. 3
5 - 5.9	2.5	Max. 3
6 - 6.9	2.75	Max. 3
7 - 7.9	3	Max. 3
8 - 8.9	4	Max. 4
9 - 9.9	4	Max. 4
10 - 10.9	4.5	Max. 4
11 - 12	4.5	Max. 5

EXAMPLE OF HOW TO READ THE MAXIMUM FIRING VOLUME

According to the 600 Max's CE marking plate, the stove's nominal output is 5.8 kW (see CE marking plate).

As the table shows, the maximum volume of wood that may be burned per hour is 2.5 kg, dispersed over three pieces of firewood (see table section below).

If the amount of wood burned exceeds this, the stove is deemed to have been overfired and the warranty will cease to apply.

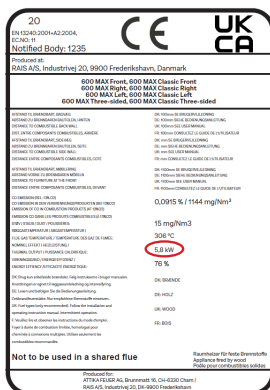

Nominal output, kW	Max. kg of wood per hour	Number of pieces of firewood
5 - 5.9	2.5	Max. 3

READ THE NOMINAL OUTPUT ON THE CE MARKING PLATE

Warning!!

If the firewood is only burning slowly without flames or is smoking, and too little air is added, unburned exhaust gasses are developed. Exhaust gasses can be ignited and explode, leading to damage to material and possibly personal injury.

Sample photos



If there are only a few embers remaining you must light the fire again.

If you just add firewood the fire will not be lit, but unburned exhaust gasses will develop.



Here firewood has been added to an ember layer which is too small, and the air flow is too small - smoke is developed.



Avoid heavy smoke - danger of exhaust gas explosion.

In case of very heavy smoke, open the door and light the fire again.

Cleaning and care

Glass

Most woodstoves use a ceramic glass product which is resistant to heat but requires cleaning to keep its appearance.

Soot or opaque marks can easily be cleaned if the marks are fresh, however if you leave the glass dirty for any length of time the acid from the wood can etch the surface of the glass permanently (wet unseasoned wood, soft wood such as used in the building industry, pallet wood should be avoided).

Only clean when cold.

Use only stove glass cleaners to remove heavy tar/ soot deposits.

All other marks can normally be removed with a damp cloth, then dry with a clean cloth or newspaper, do not let the glass dry before applying a dry clean cloth.

With more stubborn marks i.e. opaque areas/frosting, you need put a small amount of wood ash on a clean damp cloth. If the opaque mark/frosting doesn't come out, contact your dealer for a special remover.

Paint finish

The appliance has been coated with a high temperature paint which can last for years. Do not clean with a damp cloth or any cleaning products as they can cause rust or discolouration. Only clean when cold use a brush with soft bristles or dust with a lint free cloth.

Only re-spray when necessary.

The wood burning stove and the chimney must be serviced by a chimney sweep twice a year. During cleaning and care, the stove must be cold.

Prolonged period of non-use:

If the stove is to be left unused for a prolonged period of time then it should be given a thorough clean to remove ash and unburned fuel residues. To enable a good flow of air through the appliance to reduce condensation and subsequent damage, leave the air controls fully open.

Prior to a new heating season, it should be checked that the chimney and smoke gas connector are not blocked.

Maintenance/spare parts

Especially movable parts wear down during frequent use. Door seals are also wear parts. Only use original spare parts. We recommend service performed by your dealer after completion of a heating period.

Combustion chamber lining

The combustion chamber lining protects the body of the wood-burning stove against the heat from the fire. The large temperature fluctuations may result in cracks in the plates of the combustion chamber lining, which however have no effect on the functional capacity of the wood-burning stove. They do not have to be replaced unless they are crumbling away due to many years of use. The plates of the combustion chamber lining are only inserted and are easy to replace by your dealer or yourself.

Movable parts

Door hinges and door locks must be lubricated as required. We recommend that only our own lubricating spray is used, as the use of other products may lead to the formation of odours and residues. Contact your dealer to obtain the lubricating spray.

Cleaning the combustion chamber

Scrape/shovel the ash out and store it in a non-flammable container until it has cooled down. You can dispose of ash with your normal household waste.

REMEMBER!!

Never remove all the ashes from the combustion chamber - the wood will burn at its best with a layer of ashes of approx. 20 mm.

Cleaning of flue ways

In order to gain access to the smoke flue, remove the upper plate – baffle plate made of vermiculite and the smoke barrier (steel plate).

Carefully remove the baffle plate by lifting off the plate and pulling it forward.



Then, lower the front corner and carefully pull out the plate.



The smoke barrier rests on 2 pins in the back and 2 spikes in the fitting in the front.

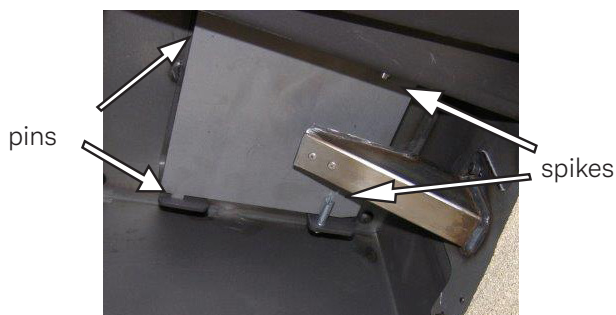

Lift off the smoke barrier, pull forward, lower and remove.



Remove dirt and dust, and mount the parts in reverse order.



NOTE!!

Be careful when replacing the smoke converter plate and smoke chikane

Interruption of operation

Smoke spillage around door

could be due to too low draught in the chimney $<12\text{Pa}$

- check whether the flue or chimney is blocked
- check whether the extraction hood is switched on; if it is, switch it off and open a window/door in the proximity of the stove for a short while.

Soot on glass

could be caused by

- the firewood is too moist.

Make sure that the stove is heated properly when firing up, prior to closing the door.

Stove is burning too strong

could be caused by:

- leak around the door seal
- chimney draught too large $>22\text{ Pa}$, draught control regulator should be installed.

Stove is burning too weakly

could be caused by:

- too small amount firewood
- too little air supply for room ventilation
- unclean smoke channels
- leaky chimney
- leakage between chimney and flue

Low draught in chimney

could be caused by

- temperature difference is too small, e.g. due to poorly insulated fluepipe
- outdoor temperature is high e.g. in the summer
- no wind
- chimney is too short or is on the lee side
- false air draught in chimney
- chimney or flue pipe is blocked
- high-density housing (lack of fresh air intake)
- negative smoke draught (poor condition)

In case of cold chimney or difficult weather conditions you can compensate by adding more fresh air (open the damper) to the stove than usual.

If your stove continues to malfunction, we recommend that you contact your RAIS distributor or chimney sweep.

WARNING!!

If incorrectly or too damp firewood is used, it can lead to excessive formation of soot in the chimney and possibly a chimney fire:

- in this case shut off all air supply from outside (if installed) to the stove
- contact the fire department
- **never** attempt to put out fire with water!
- afterwards, you should ask your chimney sweeper to check the stove and chimney

IMPORTANT!!

- to ensure safe burning there must be clear yellow flames or clear embers at all times.
- the firewood should not be smouldering.

Accessories Q-BE

8142390 - Swivel base connection

1617001 - Heat accumulation stone

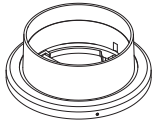

Air kit 5 (wall) 000651705xx/1 (xx: optional color code)

Air kit 32 (floor) 00065173290

Spare parts Q-BE

If spare parts other than those recommended by RAIS are used, the warranty is voided. All replaceable parts can be bought as spare parts from your RAIS distributor.

For reference see spare parts drawing (front of manual).

Pos.	Quantity	Part no.	Description
1	1	1611090	Glass door
2	1	1611190	Steel door
3	1	1612200	Fire brick set
4	1	1015500	Seal set for glass door
5	1	61-00	Flue collar 6"
6	1	1610990	Air damper
7	1	261060290	Top plate (black)
8	1	1611890	Closing mechanism (top)
9	1	1611891	Closing mechanism (bottom)
10	1	61-105	Flue collar 5"
11	1	1611590	Closing mechanism for swivel base
12	1	1611010MON	Door lock complete
13	1	9501309	BA1 spring

CHAUFFEZ EN RESPECTANT L'ENVIRONNEMENT!

3 conseils pour une combustion raisonnable et respectueuse
- une question de bon sens aussi bien pour l'environnement
que pour votre porte-monnaie

1. Allumage efficace. Utilisez de petits morceaux de bois (de sapin) et une briquette d'allumage appropriée, par exemple de la laine ou sciure de bois paraffine.
2. Utiliser seulement un peu brûlure à la fois - il offre la meilleure combustion.
3. N'utiliser que du bois bien sec - c'est-à-dire avec un taux d'humidité d'environ 15 à 20%

RECLYCLAGE

Le four est emballé dans l'emballage de récupération.
L'emballage doit être emporté selon la réglementation nationale concernant l'élimination des déchets.

Le verre ne peut pas être recyclé.

Le verre doit être jeté avec les déchets résiduels de la céramique et de la porcelaine.

Le verre résistant à la chaleur a une température de fusion plus élevée et ne peut donc pas être réutilisé.

Veillant à ce que le verre résistant à la chaleur ne finisse pas parmi les produits repris, est une aide et une contribution importante à l'environnement.

attika[®]
FEUERKULTUR

ATTIKA FEUER AG
Brunnmatt 16
CH-6330 Cham
Switzerland
www.attika.ch

RAIS[®]
ART  OF FIRE

RAIS A/S
Industrivej 20
DK-9900 Frederik-
shavn
Denmark
www.rais.com

THE ORIGINAL

Rev	Dato	Tekst
7	10-03-2023	Lighting the fire dicription changed in the German languge to leave out "leaving the door ajar"